

Instruction Manual

GM Survey Meter

Model 493

Serial No. _____

**Part No. 493-1
Rev. C**

**Published 1/89 by
VICTOREEN, INC.
Printed in U.S.A.**

PROCEDURES, WARNINGS, AND CAUTIONS

The equipment described in this manual is intended to be used for the detection and measurement of ionizing radiation. It should be used only by persons who have been trained in the proper interpretation of its readings and the appropriate safety procedures to be followed in the presence of radiation.

Although the equipment described in this manual is designed and manufactured in compliance with all applicable safety standards, certain hazards are inherent in the use of electronic and radiometric equipment.

WARNINGS and **CAUTIONS** are presented throughout this document to alert the user to potentially hazardous situations. A **WARNING** is a precautionary message preceding an operation which has the potential to cause personal injury or death. A **CAUTION** is a precautionary message preceding an operation which has the potential to cause permanent damage to the equipment and/or loss of data. Failure to comply with **WARNINGS** and **CAUTIONS** is at the user's own risk and is sufficient cause to terminate the warranty agreement between Victoreen and the customer.

Adequate warnings are included in this manual and on the product itself to cover hazards that may be encountered in normal use and servicing of this equipment. No other procedures are warranted by VICTOREEN. It shall be the owner's or user's responsibility to see to it that the procedures described here are meticulously followed, and especially that **WARNINGS** and **CAUTIONS** are heeded. Failure on the part of the owner or user in any way to follow the prescribed procedures shall absolve VICTOREEN and its agents from any resulting liability.

Indicated battery and other operational tests must be performed prior to each use to assure that the instrument is functioning properly. If applicable, failure to conduct periodic performance tests in accordance with ANSI N323-1978 (R1983) **Radiation Protection Instrumentation Test and Calibration**, paragraphs 4.6 and 5.4, and to keep records thereof in accordance with paragraph 4.5 of the same standard, could result in erroneous readings or potential danger. ANSI N323-1978 becomes, by this reference, a part of this operating procedure.

READ YOUR INSTRUCTION MANUAL

WARRANTY

This instrument with its accessories, excluding those accessories listed below, is warranted by VICTOREEN, INC., against defects in materials and workmanship for a period of one year from the date of original shipment. During the warranty period VICTOREEN will repair or, at its option, replace at no charge an instrument containing such defect, provided that it is returned, transportation prepaid, to an authorized VICTOREEN service facility. Instruments repaired under warranty will be returned transportation prepaid.

In addition, the nuclear radiation calibration (when applicable) for each instrument is warranted to be within its specified accuracy at the time of shipment. If an error in this initial calibration is discovered, the instrument will be recalibrated at no charge, provided it is returned as described above. This does not apply to any calibration deviation that may result from normal use.

There are no warranties, expressed or implied, including without limitation any implied warranty of merchantability or fitness, which extend beyond that stated here. This expressed warranty excludes coverage of, and does not provide relief for, incidental or consequential damages of any kind or nature, including, but not limited to loss of use, loss of sales or inconvenience. This exclusive remedy of the purchaser is limited to repair, recalibration, or replacement of the instrument at VICTOREEN's option.

This warranty does not apply if the product, as determined by VICTOREEN, has been damaged by accident or misuse, or as a result of service or modification by other than an authorized VICTOREEN service facility. This warranty is void if the unit is subjected to temperatures above 55°C unless otherwise indicated.

This warranty specifically excludes the following items which are covered by their original manufacturers' warranties: Photomultiplier tubes, Geiger and proportional tubes, crystal and other solid-state detectors, batteries, and major ancillary items of instrument systems, such as, but not limited to, recorders and pumps.

INSPECTION AND MATERIAL RETURN INSTRUCTIONS

Instruments should be examined and tested as soon as received by the purchaser. Claims for damage, if any, should be filed at once with the carrier. Any material returned for repair must be accompanied by a valid customer purchaser order, identifying the work to be done. A Return Materials Form is provided at the back of this manual. Send the completed form with items returned for repair to enable our Sales Personnel to process the order as quickly as possible.

Material valued at \$200.00 or more and/or weighing more than twenty pounds should be shipped the best way prepaid and fully insured.

Victoreen suggests that any instrument weighing over twenty pounds be wrapped in heavy kraft paper and packed in a double corrugated carton or wooden box. Protect the instrument on all sides with at least three inches of excelsior or similar padding. Mark the case plainly with suitable caution warnings to insure careful handling.

TABLE OF CONTENTS

	<u>Page</u>
Section 1 - Introduction	1
General Description	1
Physical Description	1
Specifications	2
Section 2 - Operation	7
Introduction	7
Installation	7
Detector probe Connection	7
Phone Connection	7
Carrying strap	7
Battery Check	7
Operational Check	7
Meter Readings	8
Selecting a Range	8
Audio Measurements	8
Section 3 - Circuit Description	11
Functional Overview	11
Geiger-Mueller Tube	11
Pulse shaping Circuit	11
Metering	11
Power Supply	12
Section 4 - Calibration	15
Introduction	15
Test Equipment Required	15
Preliminary	15
Power Supply	15
Exposure Calibration	15
Signal Electronics	16
Section 5 - Maintenance	17
Batteries	17
Replacing a GM Tube	17
Section 6 - Replaceable Parts	21

LIST OF FIGURES

<u>No.</u>	<u>Title</u>	<u>Page</u>
1	Model 493 Survey Meter with Prober	1
2	Victoreen Detector Probes	3
3	Model 491-40 Energy Response Graph	5
4	Model 491-30 Energy Response Graph	5
5	Model 489-4 Energy Response Graph	6
6	Model 489-35 Energy Response Graph	6
7	Model 493 Schematic Diagram	18
8	Model 493 Board Assembly Drawing	19

LIST OF TABLES

<u>No.</u>	<u>Title</u>	<u>Page</u>
1	Model 493 Specifications	2
2	Probe Specifications	4
3	Statistical Error	9
4	Internal Signals	16

Section 1 - Introduction

General Description

The Victoreen Model 493 is a portable, battery operated, radiation survey meter. When used with the proper detector probe, the Model 493 can be used to measure low-level alpha, beta, and/or gamma radiation. Dual meter scales permit direct reading of exposure, in milliroentgens per hour (mR/h), or count rate, in counts per minute (cpm).

Physical Description

The survey meter is housed in a ruggedized instrument case consisting of a drawn steel bottom and die cast aluminum top fastened together with pull catches. A detector probe is connected to the instrument with a high voltage coaxial connector. The clamp type carrying handle provides a convenient storage area for the probe. A low intensity beta check source is located on the side of the case; it can be used to verify that the instrument is operational. Visual readout is provided on a military type, waterproof, 3-1/2 inch panel meter with color coded scales calibrated in milliroentgens per hour and counts per minute. A phone jack is provided for use with an accessory headphone set or portable speaker when audible indication of count rate is desired. The single instrument control, a range selector switch, is a rotary switch located on the top of the instrument. This switch has an off, a battery check, and three overlapping range positions. The batteries are retained in an impact resistant, battery box that is impervious to battery fluids. Average battery lifetime is 150 hours for intermittent operation. No tools are required for battery replacement.

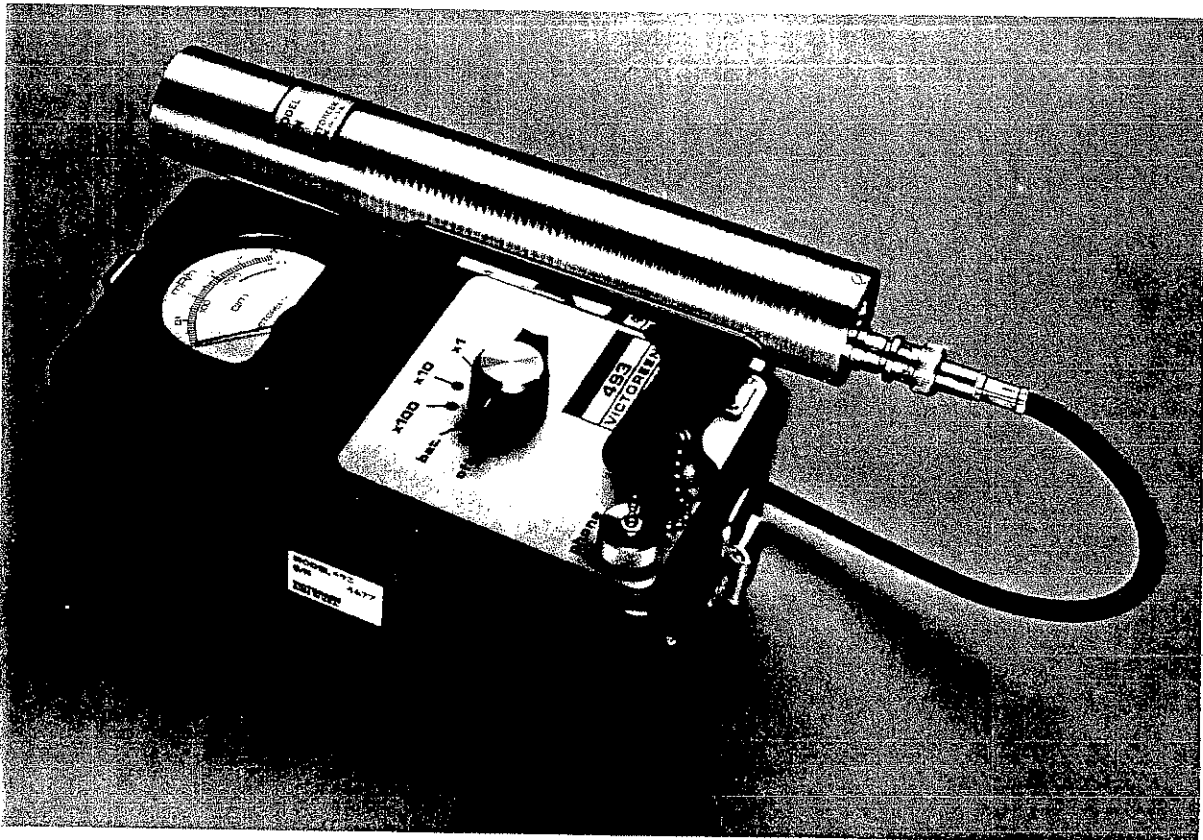

Figure 1. Model 493 Survey Meter with Probe

Specifications

Specifications for the Model 493 Survey meter may be found in Table 1. Victoreen probes that may be used with the model 493 are shown in Figure 2. Specifications for the probes are given in Table 2.

Table 1. Model 493 Specifications

Range	0 to 0.5, 0 to 5, 0 to 50 mR/h 0 to 300, 0 to 3,000, 0 to 30,000 cpm
Accuracy	±20% of full scale (referenced to ¹³⁷ Cs).
Response Time	10 seconds, nominal. (10% to 90%)
Temperature Range	-20 °F to 120 °F (-29 °C to 49°C). Alkaline batteries recommended when operating temperature is below 32°F (0 °C).
Battery Complement	NEDA 13; 1.5 volt D-cell (2 required). Part No. 16-4
Battery Life	150 hours (4 h/day, carbon-zinc cells)
Controls	Range switch: 5 positions: Off, Bat, X100, X10, X1.
Energy Dependence	Dependent upon detector probe (refer to Table 2).
Receptacles	Detector probe: MHV UG-931/U Phone: Amphenol 75-PCIM.
Construction	Splash-proof, shock-proof, two piece, all metal case.
Dimensions (H x W x L)	6 5/8 in. x 4 1/2 in. x 8 3/4 in. (16.8 cm x 11.4 cm x 22.2 cm)
Weight	Net: 3.5 lbs (1.6 kg), without probe. Shipping: 7.5 lbs (3.4 kg)
Optional Equipment	Portable speaker: Model 490-50 Headphone set,: Model 490-4

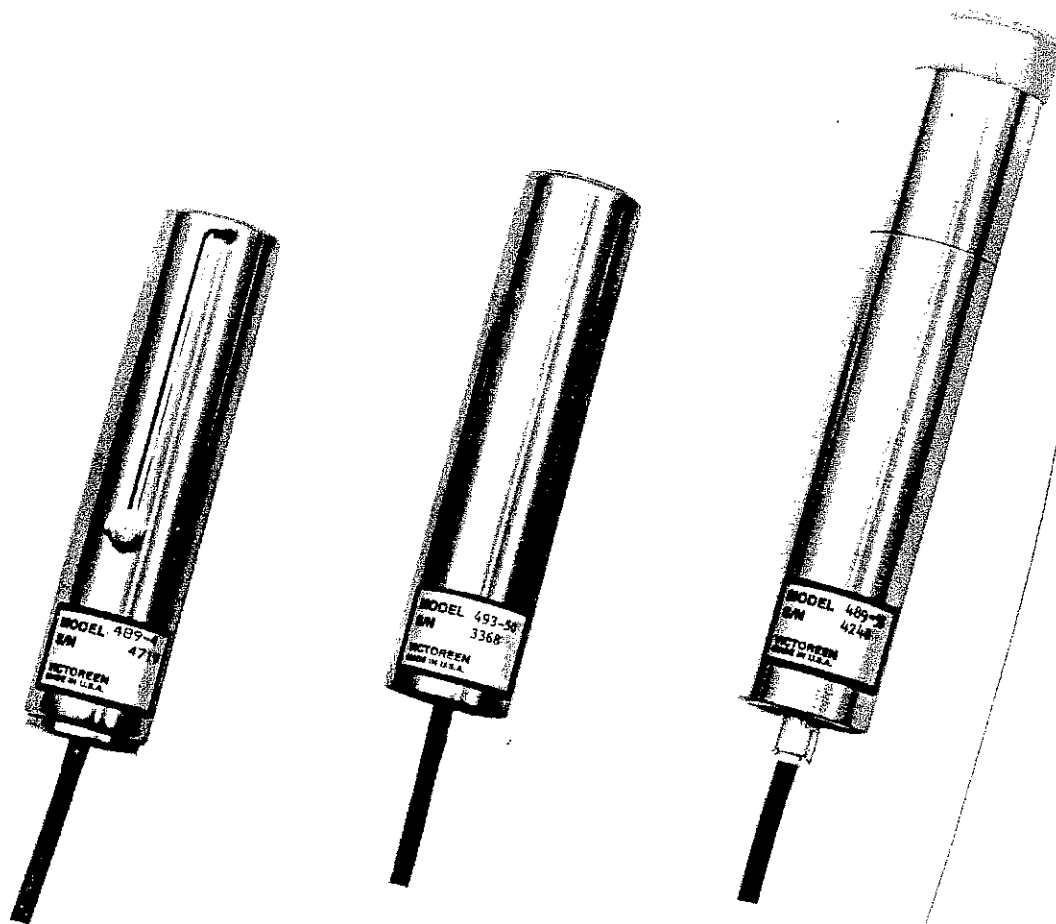

Figure 2. Victoreen Detector Probes

Table 2. Probe Specifications

Model 491-40 (Standard)	Applications: Beta, gamma . Active length: 2 1/4 in. (5.7 cm). Construction: 30 mg/cm ² stainless steel wall. Type: VG-41 GM tube Energy Response: Figure 3.
Model 493-50 (Standard)	Applications: Beta, gamma . Active length: 1 3/8 in. (3.5 cm). Construction: 30 mg/cm ² stainless steel wall. Type: VG-41 GM tube Radiation detected: Gamma above 12keV, Beta above 200 keV
Model 491-30 (Compatible)	Applications: Beta, gamma . Active length: 2 3/8 in. (6 cm). Construction: 30 mg/cm ² stainless steel wall. Type: 35-150 GM tube Energy Response: Figure 4 Standardization Factor: 2.3.
Model 489-4 (Compatible)	Applications: Beta, gamma ; good low energy response. Active length: 2 3/4 in. (7 cm). Construction: 30 mg/cm ² aluminum wall. Type: 1B85 GM tube Energy Response: Figure 5. Standardization Factor: 5.3.
Model 489-35 (Compatible)	Applications: Alpha, beta, gamma ; good low energy response. Active length: 4 in. (10.2 cm). Construction: 1.4 mg/cm ² mica end window . Type: VG-40 GM tube Energy Response: Figure 6. Standardization Factor: 5.1.
Model 489-110C (Compatible)	Applications: Alpha, beta, gamma. Active length: 1 1/2 in. (3.8 cm). Construction: 1.4 mg/cm ² mica window. Type: P-115 GM tube, pancake Energy Response: Figure 5. Standardization Factor: 5.3. Radiation detected: Alpa above 3.5 MeV; Gamma above 6 keV, Beta above 35 keV

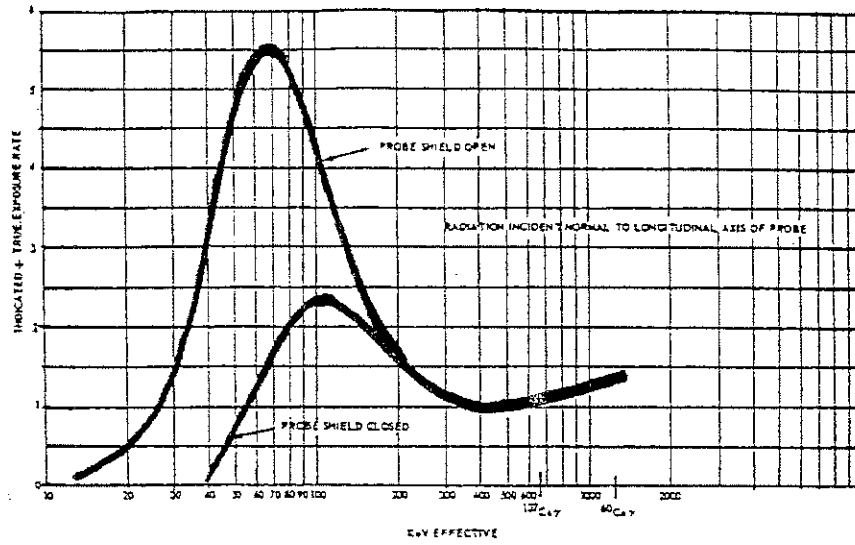

Figure 3. Model 491-40 Energy Response Graph

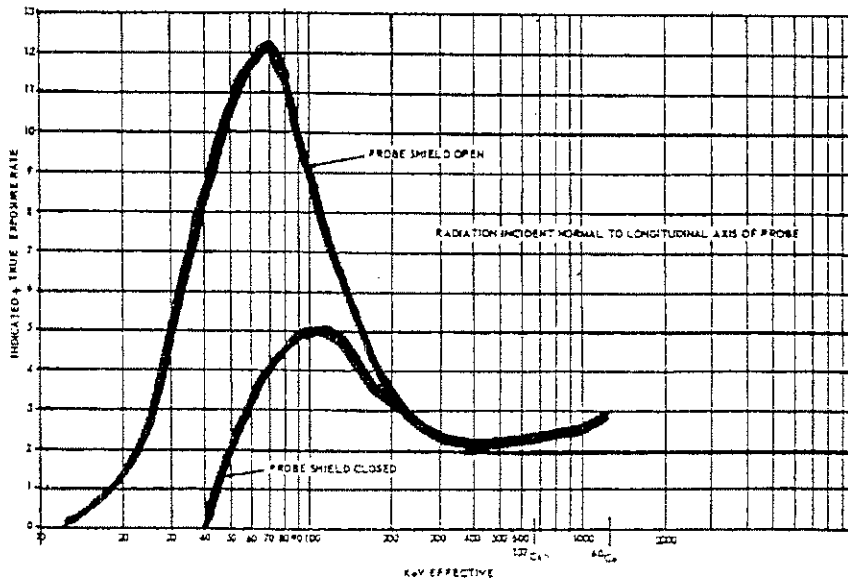

Figure 4. Model 491-30 Energy Response Graph

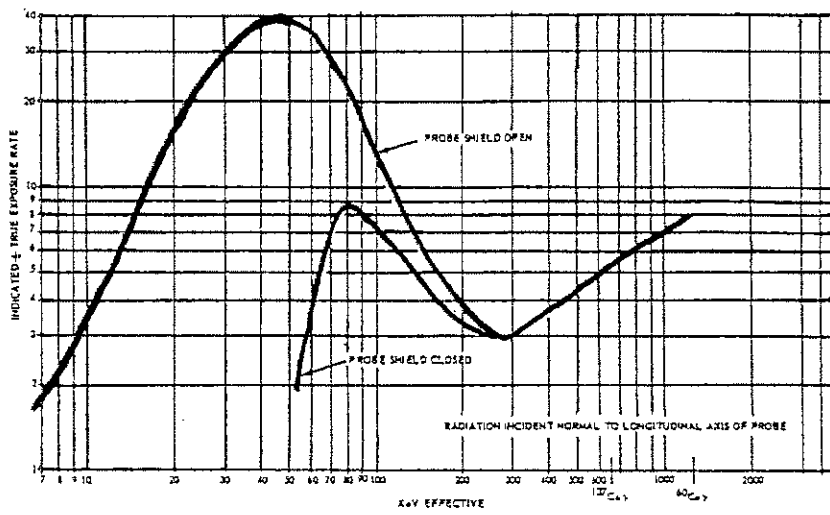

Figure 5. Model 489-4 Energy Response Graph

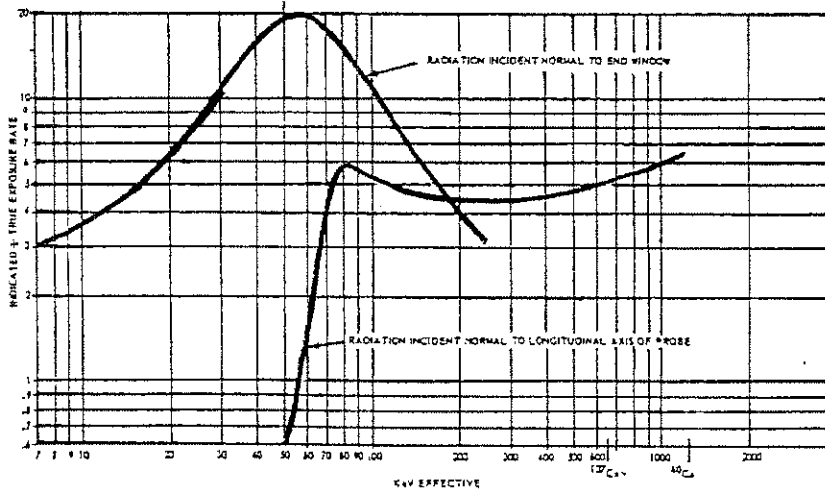

Figure 6. Model 489-35 Energy Response Graph

Section 2. Operation

Introduction

This section describes the installation and operation of the Model 493 radiation survey meter, detector probes and accessories.

Installation

The instrument is shipped from the factory with batteries installed. Prior to placing the instrument into service, it is only necessary to connect the detector probe and, if used, any accessory items.

Detector Probe Connection

Shut off the instrument. Insert the plug attached to the probe cable onto the coaxial receptacle located just to the right of the handle post. Press down, turn clockwise about 1/4 turn until the plug locks to the receptacle, then release.

Phone Connection

Unscrew and remove the protective cap located just to the left of the handle post. Attach the plug from either the headphone set or portable speaker to the receptacle. Whenever these accessories are not used, the cap should be installed in this receptacle.

Carrying Strap

The carrying strap is attached to the anchor loops cast into the top of the instrument case. Length of the strap is adjusted by the amount of strap pulled through the strap buckles.

Battery Check

The condition of the batteries should be checked prior to using the instrument. This is easily accomplished by placing the range switch in the BAT position. If the batteries are good, the meter will deflect into the battery check band; otherwise, the batteries must be replaced.

Operational Check

A low intensity beta check source is fastened to the side of the instrument case. This source may be used with any of the Geiger-Mueller tube detector probes to verify instrument operation and calibration. This check must be performed in an area that is free of any appreciable radiation fields originating from other sources.

When the Model 491-40, 491-30 or 489-4 beta-gamma probe is used, retract the beta shield to expose the perforated guard of the GM tube. One of the square openings in the guard near the center of the tube is then placed directly over the circle on the check source. A reading of approximately 2000 cpm will result for a properly operating instrument.

When the Model 489-35 probe is used, remove the plastic alpha and beta cap from the end of the probe. Place the end of the probe on the circle of the check source. A reading of approximately 2700 cpm will be obtained.

If the operational check is repeated periodically and a record of the count rate obtained for a specific combination of probe and instrument is recorded, then the calibration constancy may be determined by comparing the results.

Meter Readings

The meter has two calibrated scales. The black scale, calibrated in counts per minute (cpm), displays the radiation intensity due to alpha, beta, and/or gamma sources.

To determine the actual measurement, multiply the meter reading by the Range switch setting. For example, if the meter indicates 150 cpm and the Range switch is set to 10, then the measured intensity is $(150) \times (10)$ or 1,500 cpm.

The red scale, calibrated in milliroentgens per hour (mR/h), displays the exposure resulting from hard gamma radiation, such as that produced by ^{137}Cs , ^{60}Co , and ^{226}Ra .

To determine the indicated exposure, multiply the meter reading by the Range switch setting. For example, if the meter indicated 0.2 mR/h, and the Range switch is set to X10, then the measured exposure is $(0.2) \times (10)$ or 2 mR/h. The indicated exposure is equal to the actual exposure only when the Model 491©40 detector probe is used with the instrument.

If any other detector probe is used to obtain an exposure measurement, the indicated measurement must be divided by a standardization factor in order to obtain the actual exposure. The reason for this is that radiation detectors respond differently to different radiation energies. The standardization factor is easily obtained from the energy response graph of the detector probe in use.

For example, a Model 489-35 detector probe is used to measure gamma radiation referenced to ^{137}Cs . By using the Model 489-35 energy response graph, an exposure standardization factor of 5.1 is obtained for the conditions specified. If the indicated measurement was 50 mR/h, as in the previous example, then the actual exposure is $(50)/(5.1)$, or 0.39 mR/h.

NOTE: The standardization factor applies only to exposure (mR/h) measurements; it is never used for count rate (cpm) measurements. The measurement of count rate is not dependent upon the detector probe used.

Selecting a Range

Place the Range switch in the highest usable position, i.e. X100. Place the probe in the environment to be measured. If the meter indicates less than 10% of full scale, switch to the next lower range. Continue this procedure until either the meter indicates above 10% of full scale or the X1 range multiplier is reached. This is the range that will produce the most accurate measurements.

Audio Measurements

An audible indication of count rate may be obtained by using either the headphone set or portable speaker with the instrument. Each radiation event at the detector probe will produce a distinctly audible click in the headphone or speaker. Due to the nature of radiation, these clicks are randomly spaced in time. It may be several seconds before a click is heard; then, there may be several in rapid succession.

Accurate measurement of background and other very low- level radiation is possible by counting the number of clicks that occur within a period of time. The count rate in cpm is obtained by dividing the number of clicks heard by the time interval in minutes. For example, if 100 clicks were counted during a 10 minute interval, then the count rate would be $(100)/(10)$, or 10 cpm.

Based on statistics, Table 3 identifies the number of counts that are required to provide a known percentage error. The standard error is defined to be that error for which the true error will not exceed the given percentage error in 68 cases out of 100. Nine-tenths error is defined to be that error for which the true reading is not different from the observed reading within the given percentage limits for 90 cases out of 100.

Table 3. Statistical Error

Percent Error	Counts Required	
	Standard Error	Nine-Tenths Error
1%	10,000	27,000
3%	1,000	3,000
10%	100	271

Section 3 - Circuit Description

Functional Overview

A regulated power supply circuit powered by internal batteries supplies the detector and survey meter electronics for the Model 493. The power supply provides a source of regulated high voltage to the detector through resistor R. When the detector is energized by incident radiation, the current flowing through R increases very briefly causing a negative pulse to appear at capacitor C. This pulse is coupled through C into the pulse shaping circuit where it triggers a monostable multivibrator which produces a constant current pulse having a duration proportional to the energy of the incident radiation. This current pulse is integrated to provide an average dc current signal that is displayed on the panel meter. An audio output signal is also provided so that incident radiation may be monitored with headphones or a portable speaker.

The following paragraphs present a detailed description of circuit operation on a stage by stage basis. Refer to the schematic and assembly drawings located in the Maintenance section of this manual.

Geiger-Mueller Tube

Radiation events are detected by the detector probe which contains a Geiger-Mueller (GM) tube. The tube consists of two electrodes, an anode and a cathode, and a mixture of inert gas. The cathode is a thin, cylindrical shell; and, the anode is a fine wire suspended along the longitudinal axis of the shell. The volume between the anode and the cathode is filled with inert gas containing a small amount of halogen gas which acts as a quenching agent.

A potential difference of 900 volts is established between the two electrodes with the anode being positive and the cathode negative. This voltage is slightly less than that required to produce a discharge in the gas.

When a photon of sufficient energy enters the GM tube, a molecule of the inert gas is ionized. Because of the potential between the electrodes, the positively charged ions are attracted to the cathode, and the negatively charged electrons are attracted to the anode. While moving toward the electrodes, these charged particles trigger the ionization of additional gas molecules. This avalanche effect causes a pulse of current to flow in the external circuit.

The length of time that the GM tube conducts current depends upon how long the gas remains ionized. The small amount of halogen gas tends to stop or quench the flow of ions. This quenching action suppresses further ionization unless additional photons enter the tube.

Each time a photon enters the GM tube with an energy sufficient to cause ionization, a pulse of current flows in the external circuit. By counting the number of pulses, it is possible to measure exposure.

Pulse Shaping Circuit

The pulse shaping circuit is a monostable multivibrator consisting of transistors Q1, Q2 and associated components. The function of this stage is to provide a uniform pulse of output current for each input pulse, regardless of the shape or magnitude of the input pulse.

As long as no pulse is provided by the GM tube, the bias is such that Q1 is cut-off and Q2 is saturated. The Range switch (S1) connects one of the timing capacitors (C5 through C7) into the circuit at the junction of R5 and R6. Since there is no current flowing through Q1, the voltage at this junction is also equal to the supply voltage; consequently, the timing capacitor assumes a charge, positive at the end near Q1, with a voltage almost equal to that of the supply voltage.

When the GM tube provides a pulse of sufficient magnitude to cause the base of Q1 to become forward biased, collector current will begin to flow. This triggers a rapid change in state so that Q1 becomes saturated and Q2 becomes cut-off.

The timing capacitor discharges at an exponential rate determined by the time constant established by the values of resistors R7, R8 and the timing capacitor. Once the capacitor is discharged, the circuit returns to the previous state where Q1 is cut-off and Q2 is saturated.

The width of the current pulse directly effects the meter reading; however, the length of time that Q1 conducts current is determined by an RC time constant. Therefore, the width of the current pulse can be controlled either by selecting a different value of timing capacitor with the Range switch, or by adjusting the value of R8, an internal calibration adjustment.

The audio output is derived by ac coupling a high impedance magnetic earphone to the collector of Q1.

Metering

The metering circuit consists of M1, R1 and integrating capacitor C8. When a pulse causes Q1 to conduct, the collector current charges the integrating capacitor. As this capacitor discharges, a small current flows through the meter causing it to deflect. The amount of deflection is proportional to the amount of charge stored, which is proportional to the duration of the input pulse. Thus, the meter reads the average current through Q1 which is proportional to the incident radiation.

When the Range switch is placed in the BAT position, R16 is connected in series with the meter to form a simple voltmeter having a range of 3.1 volts full scale. It is internally connected across the two 1.5 volt batteries which are connected in series.

Power Supply

The power supply provides 900 volts dc for detector operation as well as -7 volts dc to operate the pulse shaping electronics. These voltages are obtained with a blocking oscillator operated in the flyback mode.

The blocking oscillator portion of the circuit consists of Q3, windings 3-4 and 5-6 of T1, R3, C4, CR3, C9 and the two 1.5 volt batteries. The high voltage power supply portion of the circuit consists of winding 1-2 of T1, CR1, C2, C3, R2 and V1.

When the instrument is turned on, current flows through winding 3-4 of T1 and through the collector-emitter junction of transistor Q3. This current induces a voltage in winding 5-6 having a polarity that tends toward sustaining and increasing the conduction of Q3. Collector current continues to increase until Q3 becomes saturated, at which time the current flowing through Q3 and winding 3-4 becomes constant. When this occurs, the voltage induced in winding 5-6 becomes zero, which causes a decrease in Q3 base current. This causes the current flowing through the collector and winding 3-4 to decrease, which induces a voltage in winding 5-6 of the opposite polarity, which tends to turn off Q3. Since this is a regenerative action, the transistor turns off extremely fast causing the phototransistor flux to collapse suddenly. This flyback action induces voltage on all of the transformer windings. The magnitude of the voltage developed at each winding is proportional to the transformer turns ratio. The voltage at the base of Q3 then returns to zero, allowing the transistor to conduct again and thus repeating the cycle. The repetition rate is controlled by R3 (internal adjustment). C4 suppresses high frequency parasitic oscillations generated by the switching action of the transistor.

The voltage induced on winding 1-2, which is extremely high due to the large number of turns, is rectified by CR1 and filtered by R2, C2, and C3. It is then regulated to 900 volts by V1. The regulating action of V1 is reflected back through the transformer; consequently, the voltage induced at the other windings are also regulated.

The regulated voltage at winding 5-6 is rectified by CR3, filtered by C9, and provides a source of -7 volts to power the remainder of the instrument.

Section 4 - Calibration

Introduction

The instrument is calibrated at the factory using a Model 491-40 detector probe and a ^{137}Cs gamma radiation source. All instrument specifications and operating procedures are based on this configuration.

The instrument may be recalibrated in the field by using the procedures described in this section.

Test Equipment Required

The following equipment is necessary to recalibrate the Model 493 survey meter: source of gamma radiation, oscilloscope, electrostatic voltmeter, and a volt-ohm meter (VOM).

Preliminary

Turn the instrument off. Remove the survey meter from the case. Verify that the battery contacts are clean; then, install fresh batteries.

Power Supply

When the power supply is operating properly, a 100 Hz buzz can be heard emanating from T1, the power transformer. If this buzz is not heard, the oscillator circuit is probably not functioning and the setting of R3 should be checked.

Turn the instrument off. Set the VOM to the 100 mA range and insert it in series with the batteries. Turn R3, the high voltage adjustment potentiometer, fully counterclockwise. Turn on the instrument (the Range switch may be in any position). Turn R3 clockwise until the VOM indicates 33 mA with carbon-zinc batteries, or 30 mA with alkaline batteries. If the current is within ± 2 mA of the correct value, no further adjustment is required.

Next, verify that the high voltage output is 900 volts dc. Connect the electrostatic voltmeter between ground and the center pin of J2. If an electrostatic voltmeter is not available, this check can be performed with the VOM, as long as it has a sensitivity of at least 20,000 ohms per volt, by setting it on the 5000 volt range.

Exposure Calibration

Prior to calibrating the power supply must be operational as described under **Power Supply**.

In order to duplicate the factory calibration, a Model 491-40 detector probe and a known source of ^{137}Cs gamma radiation must be used. Calculate the distance required between the source and probe such that the exposure reading falls in the upper half of the meter scale when the Range switch is placed in the X10 or X100 position. Position the probe at this distance. Set the Range switch to the required position. Then turn R8, the calibration adjustment, until the exposure indicated on the meter agrees with the predicted exposure.

Other probes and/or isotopes may be used for calibration purposes; however, when this is the case, the energy response of the detector must be taken into account. For example, when a Model 491-30 probe and a ^{60}Co source are used, the standardization factor is about 3 (see the

energy response graph). To calibrate the instrument with this combination, adjust the calibration control so that the meter indicates 3 times the predicted exposure.

Signal Electronics

To verify that the signal electronic circuits are functioning properly, place the detector probe on the operational check source. Use the oscilloscope to verify that the internal signals are as listed in Table 4.

Table 4. Internal Signals

Test Point	Typical Measurement
Q1 Collector	Positive 7 volt square wave
Q2 Base	Positive 3.5 volt pulse, rising sharply, exponential decay
Q2 Collector	Negative 7 volt square wave

The measured pulses will occur with each input pulse. Nominal pulse widths are:
7 milliseconds on the X1 range,
799 microseconds on the X10 range, and
70 microseconds on the X100 range.

Once the instrument has been calibrated, shut off the power, remove all test equipment, and reassemble the survey meter into the case.

Section 5 - Maintenance

Batteries

The batteries must be replaced when they fail the battery check described in paragraph 3.6. This occurs when the cell voltage is below about 1 volt.

Access to the batteries is obtained by snapping open the pull catches at each end of the instrument case and removing the instrument from the case bottom. The battery box is located next to the circuit board assembly.

Squeeze the battery retainer clamp and remove it from the box. Remove the batteries and install fresh D cells observing proper polarity. If operation below 32 °F is anticipated, alkaline batteries are recommended; otherwise, zinc carbon batteries may be used. Replace the retainer clamp. Insert the instrument into the case bottom, squeeze together, and snap the two catches closed. If

the instrument is to be stored for an extended period of time, it is recommended that the batteries be removed.

Replacing a GM Tube

The following procedure may be used to replace the Geiger-Mueller tube which is located in the detector probe.

Shut off the instrument and disconnect the detector probe from the instrument. Slide the shield open and turn the latch button into the enlarged notch. Unscrew the latch bottom and slide the shield off the probe. Unscrew the perforated guard from the base section. Remove the friction sleeve by slipping it off the end of the base section.

Hold the guard in one hand and grasp the metal contact of the tube with the fingers of the other hand. While wiggling back and forth, pull the tube free. With the base unscrewed, the tube is held by a rubber gasket and the wiggling may be necessary to pull the tube free. Remove the rubber gasket from the old tube.

Slip the gasket over the base of the new tube. Using a clean dry cloth, carefully wipe off any fingerprints from the glass on the bottom of the tube. Insert the tube into the base section of the probe and replace the friction sleeve. Slide the shield into place with the enlarged locking notch toward the free end (away from the cable). Replace the locking latch button. Reconnect the probe to the instrument.

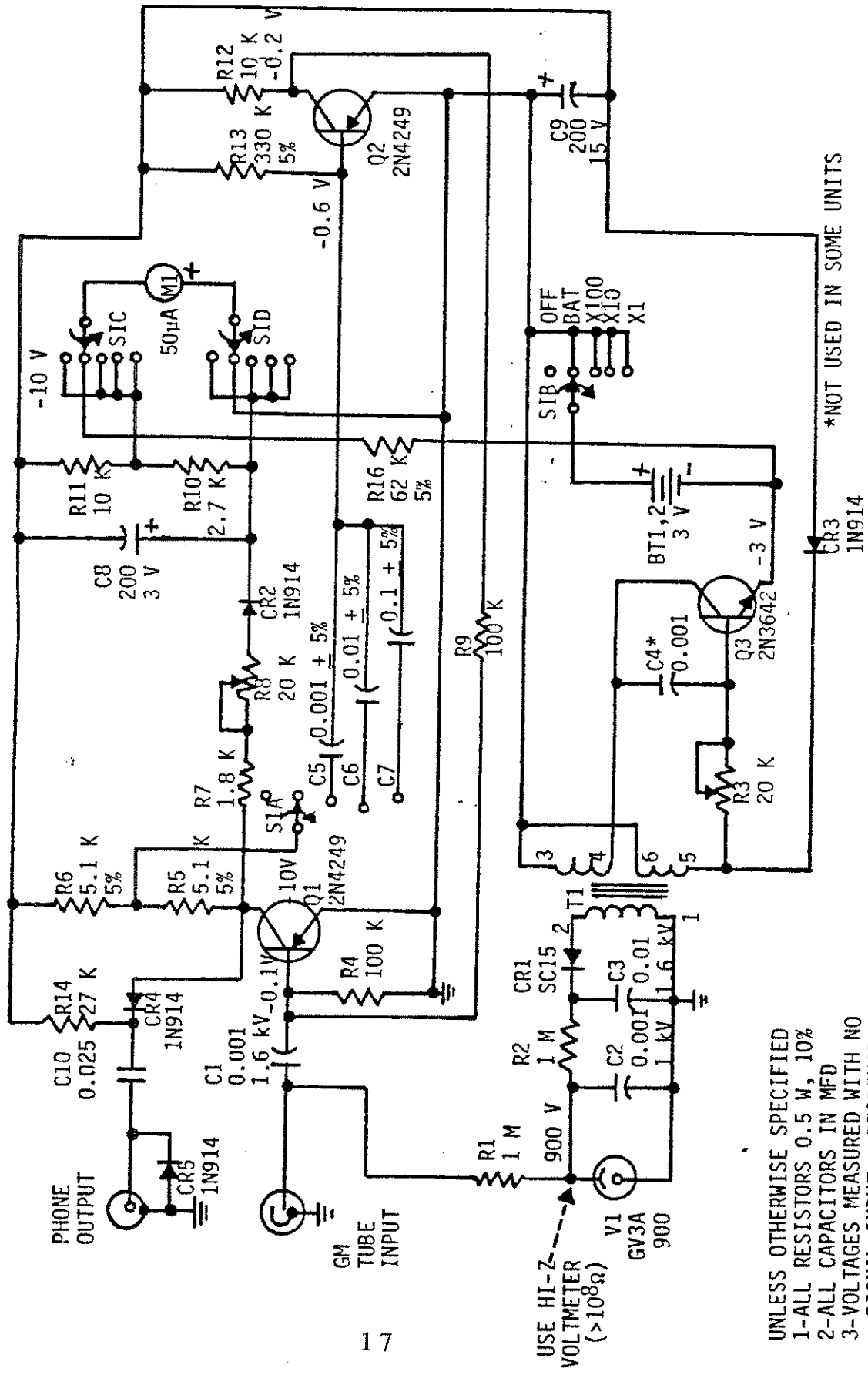

Figure 7. Model 493 Schematic Diagram

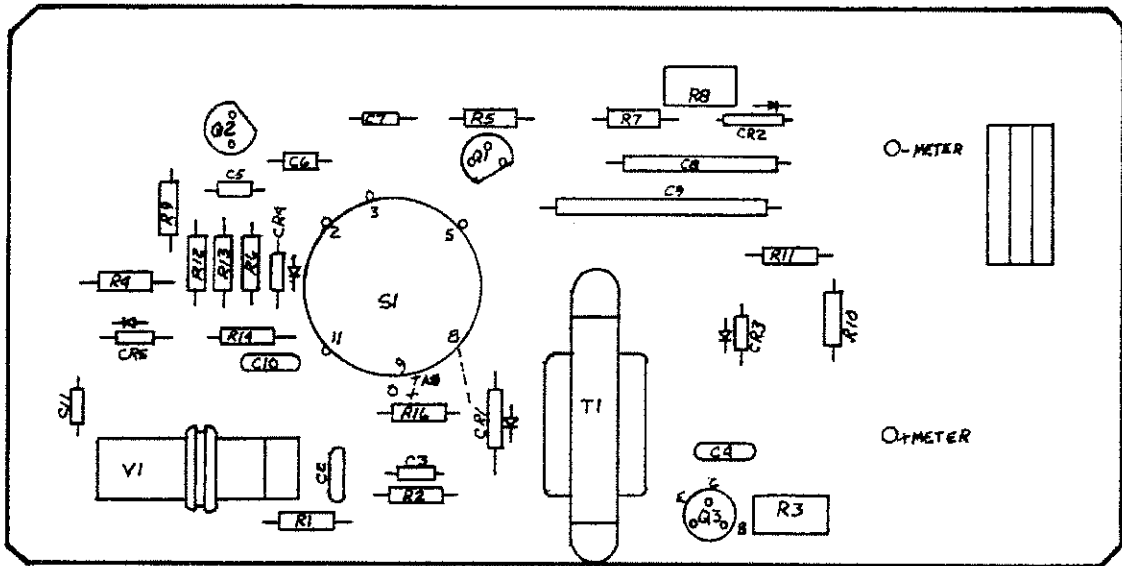

Figure 8. Model 493 Board Assembly Drawing

Section 6 - Replaceable Parts

Mechanical Replacement Parts

Description	Part No.
Case Top Assembly	493-10
Case Bottom Assembly	493-11
Clamp, Probe	489-45
Gasket, Case	720-157
Meter Assembly	493-7
Gasket, Meter	700-63
Switch, Range	492-27
Knob, Range Switch	9-48
Phone Jack	700-21
Battery, 1.5 V	16-4
Cap and Chain	489-23
Handle, Probe Stand	490-11
Battery Box	700-66
Battery Contact	700-68
Battery Box Cover	720-121
Beta Source	700-115

Electrical Replacement Parts

Reference	Description	Part No.
T1	Circuit Board Assembly	493-17
V1	Transformer	14-76
V1	Tube	GV3A/B-900
CR1	Diode, HV-15	52-38
CR2,CR3,CR4,CR5	Diode, 1N914B	52-219
C1	Capacitor, 0.001 uF, 3 kV	21-209
C2,C4	Capacitor, 0.001 uF, 1 kV	21-32
C3	Capacitor, 0.01 uF, 1.6 kV	21-23
C5	Capacitor, 0.001 uF, 200 V	21-97
C6	Capacitor, 0.01 uF, 200 V	21-94
C7	Capacitor, 0.1 uF, 200 V	21-92
C8	Capacitor, 250 uF, 6 V	21-346
C9	Capacitor, 200 uF, 15 V	21-34
C10	Capacitor, 0.02 uF, 100 V	21-192
Q1,Q2	Transistor, 2N4249	23-90
Q3	Transistor, 2N3642	23-62
R1,R2	Resistor, 1 M, 1/2 W, 5%	185-36
R3,R8	Potentiometer, 20 k	22-226
R4,R9	Resistor, 100 k, 1/2 W, 5%	185-20
R5,R6	Resistor, 5.1 k, 1/2 W, 5%	185-224
R7	Resistor, 1.8 k, 1/2 W, 5%	185-649
R10	Resistor, 2.7 k, 1/2 W, 5%	185-665
R11,R12	Resistor, 10 k, 1/2 W, 5%	185-706
R13	Resistor, 330 k, 1/2 W, 5%	185-154
R14	Resistor, 27 k, 1/2 W, 5%	185-728
R16	Resistor, 62 k, 1/2 W, 5%	185-751

VICTOREEN MATERIAL RETURN FORM

NAME OF SENDER _____

PHONE NUMBER _____

COMPANY AFFILIATION _____

STREET _____

CITY _____ STATE _____ ZIP _____

CUSTOMER ORDER NUMBER _____

VICTOREEN REGISTER NUMBER OR INVOICE NUMBER _____

DATE PURCHASED _____

MODEL NUMBER _____ SERIAL NUMBER _____

WARRANTY REPAIR YES _____ NO _____

REASON FOR RETURN _____
